

Using Thermocouple Sensors

Connecting Grounded and Floating Thermocouples

For best performance, Thermocouple sensors should be floating. This will ensure that no noise currents can flow in the sensor leads and that no common-mode noise voltage will be coupled into the controller.

The diagram below shows the input schematic for a typical Cryo-con controller and its connection to both a floating and a grounded Thermocouple sensor.

Note that the controller's input amplifier is differential so both connections to the sensor have very high input impedance. This was done to optimize the noise performance for sensors that use Four-Wire measurements.

Thermocouples do not require excitation from the controller's internal current source and cannot be connected for Four-Wire

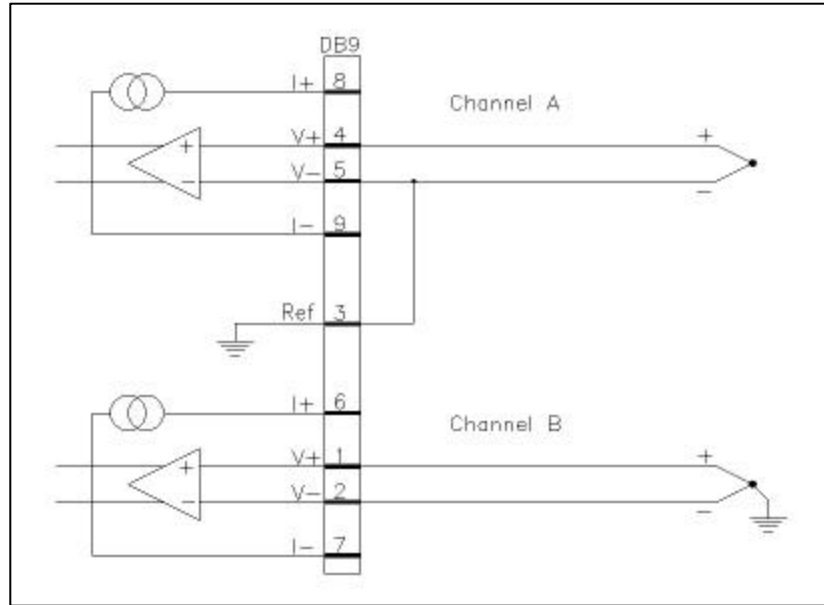

measurements. Therefore, when a floating Thermocouple is used, a ground potential reference point must be established. If this is not done, the high impedance of the input will allow the common-mode voltage of the Thermocouple to float up to the power supply rail of the amplifier and will result in erratic readings.

Floating Thermocouples

For floating Thermocouples, an external Ground Reference is established by connecting Pin 3 of the input connector to the negative sensor input pin. This is shown in the figure above for Channel A where Pin 3 is connected to Pin 5. A Ground Reference connection must be made to the negative side of each FLOATING Thermocouple connected to the instrument.

Grounding Thermocouples

The connection of a grounded Thermocouple is shown above on Channel B. Note that the external ground reference connection is NOT made at the sensor connector as it was in the floating sensor case. This is because the ground reference is established externally by the Thermocouple itself.

For this scheme to operate properly, the ground voltage established by the Thermocouple must fall within the range of the instrument's input amplifier, which is ± 5 Volts. Further,

to improve accuracy, noise on this ground, relative to the controller, should be minimized.

Since the Controller's input amplifier is very high impedance, ground-loop currents cannot flow from the grounded Thermocouple into the instrument's grounding scheme. If a ground is made at the controller, noise current could flow from the Thermocouple ground, through the leads and complete a ground loop through the connection at the controller. The result would be extremely poor accuracy and erratic readings.

If more than one Thermocouple is grounded, the noise problem is compounded. However, good performance should still be attainable if attention is paid to good quality system grounds.

Thermocouple Connection Summary

For each floating (un-grounded) Thermocouple, a connection on the controller must be made from the negative side of the sensor to the Ground Reference (Pin 3).

For each grounded Thermocouple, NO Ground Reference connection should be made.

The requirement for an external Ground Reference may seem inconvenient at first. However, if the controller established this reference internally (as many instruments do), accuracy would be reduced in either the grounded or floating Thermocouple case.

DB9 Thermocouple Connectors

The Model 34 controllers use a DB9 type connector for Thermocouple inputs. The Pinout and a REAR view of this connector is shown here.

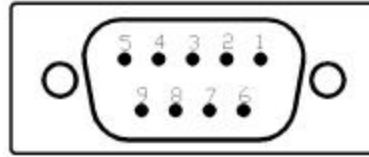

Figure 1: Thermocouple Input Connector

Thermocouple sensors require a two-wire connection to the Model 34. All thermocouple connections must be made at the sensor input connector since this connector is thermally anchored to an internal sensor that is used for Cold Junction compensation. The input connector should have a backshell installed in order to prevent local air currents from generating errors in the cold junction circuitry.

When using a standard Solder Cup type DB9 connector, connections may be soldered into the input connector.

Some types of Thermocouples are fabricated from material that is difficult to solder to. In this case, the use of crimp type connectors is recommended.

For best performance with any Thermocouple, crimp type connectors should be used where the crimp contacts are fabricated from the same type material as the Thermocouple metal itself. These connectors are available as kits from Cryo-con for Type K, T, J and E Thermocouples. Other types of Thermocouples may be supported using Copper contacts.

| Input Channel | Floating Thermocouples | | |
|---------------|------------------------|---------|-----|
| | Connector | Signal | Pin |
| ChA | Lower | V+ | 4 |
| ChA | Lower | V-, Ref | 5&3 |
| ChB | Lower | V+ | 1 |
| ChB | Lower | V-, Ref | 2&3 |
| ChC | Upper | V+ | 4 |
| ChC | Upper | V-, Ref | 5&3 |
| ChD | Upper | V+ | 1 |
| ChD | Upper | V-, Ref | 2&3 |

Table 1: Floating Thermocouple Connection

| Input Channel | Grounded Thermocouples | | |
|---------------|------------------------|--------|-----|
| | Connector | Signal | Pin |
| ChA | Lower | V+ | 4 |
| ChA | Lower | V- | 5 |
| ChB | Lower | V+ | 1 |
| ChB | Lower | V- | 2 |
| ChC | Upper | V+ | 4 |
| ChC | Upper | V- | 5 |
| ChD | Upper | V+ | 1 |
| ChD | Upper | V- | 2 |

Table 2: Grounded Thermocouple Connection

Common Error Sources

Cold Junction Compensation

Cold Junction Compensation is required for any instrument to measure Thermocouple sensors accurately. The most accurate method for performing this is by using an external 'Ice Bath' setup. However, this is usually impractical.

Cold Junction Compensation in the Model 34 controller is performed by a circuit that measures the temperature of the input connector pins. This reading is then used to look up a compensating voltage from the Thermocouple's calibration curve.

The major source of error in this process is the accuracy of measuring the temperature of the input pins. This is usually a 'tracking' type error relating to the response time of the sensor rather than an absolute error in the actual measurement. For example, if the controller itself is maintained at a very accurate ambient temperature, readings from the Thermocouple will be very accurate and stable. However, if the ambient temperature changes significantly, there will be a time lag where the measured temperature will be slightly off until the ambient temperature stabilizes again.

The backshell of the input connector should always be installed. This will minimize errors caused by local air currents.

To further minimize Cold Junction Compensation errors, it is recommended that crimp type pins made from Thermocouple metal be used in the input connector. This process is described in the previous section.

In summary, Cold Junction Compensation errors are indicated by Thermocouple temperature measurements that vary when ambient temperature changes and stabilize as ambient temperature stabilizes.

Cold Junction errors may be minimized in the Model 34 by the use of special input connectors. Further, implementing an external 'Ice Bath' correction scheme can eliminate them completely.

Calibration Errors

Variation in the manufacture of Thermocouple wire and its annealing over time can cause errors in temperature measurement.

Instruments that measure temperatures above about 0°C will usually allow the user to correct calibration errors by adjusting an offset in order to zero the error at room temperature. Unfortunately, in cryogenic applications, Thermocouples lose sensitivity at low temperatures so a single offset voltage correction is insufficient. For example, if calibration errors for a Type K Thermocouple are zeroed at room temperature, a reading near Liquid Nitrogen temperatures may have an error of 5K.

Correction of Calibration Errors over a wide range of temperature can be made by using the Model 34's CalGen feature. Here, the controller should be stabilized at both temperature extremes. Then, CalGen will generate a new sensor calibration curve that best fits the two points to the actual sensor voltage readings.

Often, CalGen is done by taking a reading at room temperature, then a second reading with the sensor in Liquid Nitrogen. Since a Thermocouple's sensitivity is relatively constant above room temperature, this procedure will give good accuracy over a wide range of temperature.

AC Power Line Noise Pickup

AC power noise pickup is indicated by temperature measurements that are significantly in error. In extreme cases, there may be no valid measurements at all.

Thermocouples have relatively high resistance leads, and each lead is made from a different material. Therefore, they are much more sensitive to AC pickup than sensors using copper wires.

A ground loop will cause significant AC coupling into the sensor. However, if the connection procedures described above are carefully followed, ground loops through the sensor leads will be avoided.

When a grounded sensor is used, a poor quality ground may have sufficient AC voltage to exceed the input range of the controller. This can often be corrected by running a copper connection from a point near the sensor ground and the chassis ground of the controller. Defective building wiring or insufficient grounding is usually the root cause of this type problem.

Most common AC noise pickup problems are caused by capacitive or magnetic coupling into the sensor wires. Again, the Thermocouple's high resistance leads make this type coupling very efficient. General recommendations to minimize coupling include:

1. Minimize the length of Thermocouple wires. For example, use a Thermocouple Module near the sensor to convert the Thermocouple wires to copper as soon as possible.
2. Twist the wires. Twisted wire for various types of Thermocouples is available from several vendors.
3. Avoid running sensor wires near, or parallel to AC power lines.
4. Use the largest diameter sensor wires possible (Lowest AWG). This will reduce the lead resistance and, therefore, reduce coupling. However, in many cryogenic applications, wire size must be kept small because Thermocouple wire is a good heat conductor.

Grounded Thermocouple Issues.

Assuming that a grounded Thermocouple is properly connected, as described above, the controller should operate properly. If this is not the case, the problem can usually be tracked to the ground connection made at the sensor relative to the ground at controller.

As noted above, the ground potential at the Thermocouple sensor must fall within the ± 5 volt input range of the controller.

Usually, the voltage difference between the sensor ground and the controller's ground is an AC power line signal. It can be seen with a battery powered AC voltmeter connected between the controller's chassis and a ground point near the sensor.

If there is a significant voltage difference, a safety hazard may be present. Building wiring should be tested before proceeding.

A voltage difference caused by a loose, or non-existent, ground reference can be corrected by:

1. Establishing a good quality ground point that the controller and sensor grounds are both connected to.
2. Running a ground strap. The preferred connection of the ground strap would be from a ground point near the sensor to the Third-Wire ground connection of the controller's AC power cord. If this is not available, the strap can be connected to the controller's chassis.

©2001 Cryogenic Control Systems, Inc. All Rights Reserved.
Cryogenic Control Systems, Inc
PO Box 7012
Rancho Santa Fe, CA 92067
Tel: (858) 756-3900 FAX: (858) 759-3515
E-mail: sales@cryocon.com
Web: www.cryocon.com